

Hitachi UltraHigh-resolution Field-emission  
Scanning electron microscope  
SU8700

**HITACHI**  
Inspire the Next

# SU8700

SCANNING ELECTRON  
MICROSCOPE



# SU8700 Modern Solutions for a Modern World

The SU8700 brings in a new era of Ultrahigh-resolution Schottky field emission scanning electron microscopes to the long-standing Hitachi EM line-up. This revolutionary FE-SEM platform incorporates multifaceted imaging, high-probe current, automation, efficient workflows for users of all experience levels, and more.



\* The instrument picture includes options

## Key feature of The SU8700

---

### 1 Enhanced User-Experience with Advanced Automation

- Automated alignments increase efficiency and throughput.
- Automated data acquisition recipes allow for greater precision as well as repeatability.
- High-precision piezo stage\* improves navigational and recall accuracy for targeted regions of interest.

### 2 Ultrahigh-Resolution and Analytical Capability

- Hitachi's Schottky emitter provides ultrahigh-resolution images and ultra-fast microanalysis with high probe current.
- 0.01 kV\* imaging capability without stage bias expands the application range for beam sensitive specimens.
- A multitude of new detectors and options are available to best suit the needs of any user.

### 3 New Display and Interface Features

- Dual monitor configuration supports a flexible and highly efficient workspace
- Display and save 6 signals simultaneously in order to acquire more information in less time.
- Acquire up to **40,960 x 30,720** pixels of high-resolution information.\*

(\*) option

# Electron Optics and Detectors

The SU8700 allows for both versatile imaging and demanding analytical capabilities in a single system.

- Schottky field emitter provides probe current from a few pA to 200 nA, in order to address a large variety of specimens.
- Novel electron optics enable very low voltage imaging while still maintaining high image quality – even as low as 0.01 kV\* without stage bias.
- Optimized detection system and chamber design allow short working distance EDS analysis (WD=6 mm) for both imaging and analysis under the same parameters.

## Upper Detector (UD)

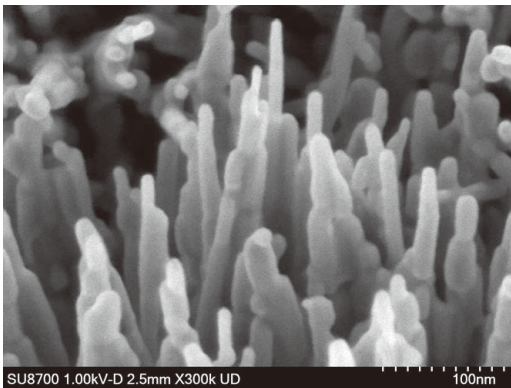

The new UD is well-suited for fine structure imaging by utilizing superior low-energy signal collection. The image above shows nano-scale morphological information of needle-like TiO<sub>2</sub> with tip radii of less than 10 nm.

Specimen courtesy of Prof. Che Shunai,  
School of Chemistry and Chemical Engineering, SJTU

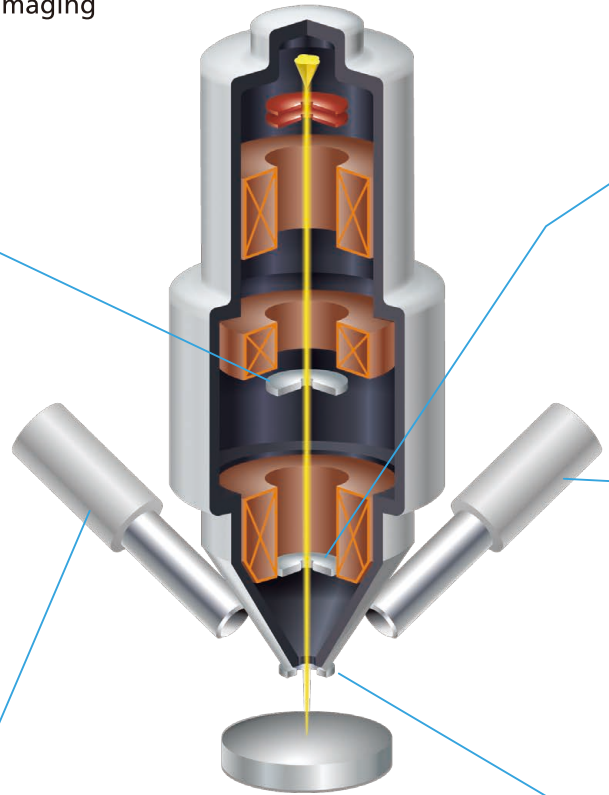

## Ultra Variable-Pressure Detector (UVD)\*

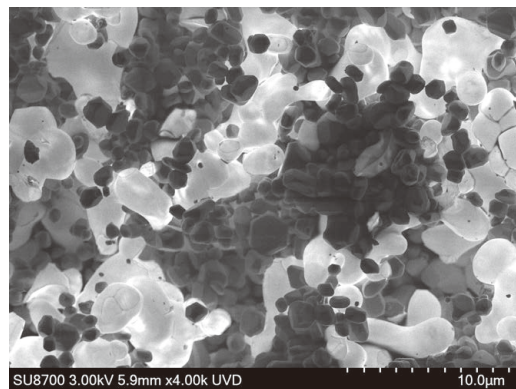
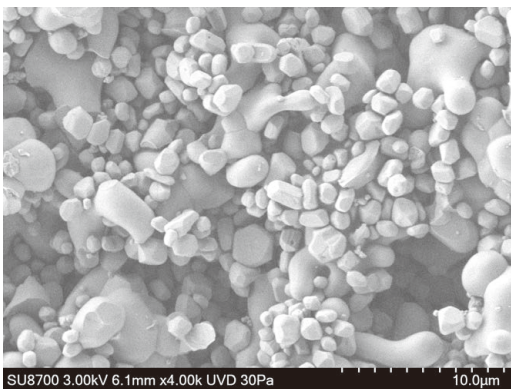

The SU8700's unique UVD collects photonic signals in order to provide information beyond traditional EM methods. The left image demonstrates the UVD being used as a variable-pressure SE detector which in order to display surface and morphological information of this specimen. Whereas the right image demonstrates the UVD operating as a Cathodoluminescence detector under high vacuum conditions to clearly show the distribution of the fluorescent pigments.

## Middle Detector (MD)\*

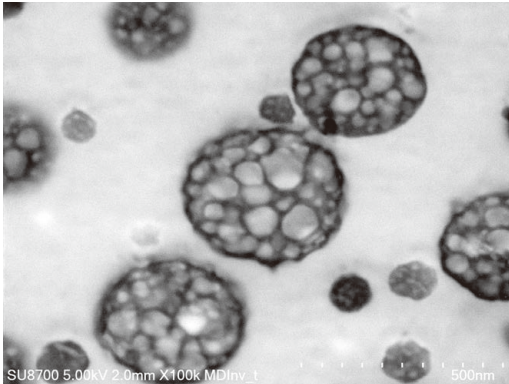

Backscatter electron (BSE) imaging is a powerful tool for acquiring compositional information of specimens. The image on the left shows a Salami structure stabilized by stained ABS resin with the SU8700's MD. The SU8700's MD allows for TEM-like data acquisition and even works at voltages lower than 0.5 kV.

## Lower Detector (LD)

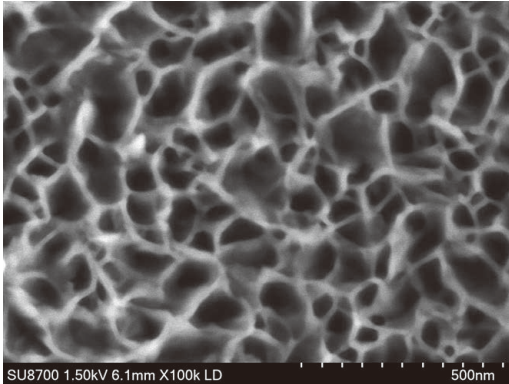

The ability to visualize high-quality topographical information is an essential capability for all modern SEM platforms. The SU8700 LD enables acquisition of topographical information with outstanding detail, speed, and definition. The image left on the left reveals surface topographical information of anodized aluminum oxide.

## Semiconductor Type BSED (PD-BSED)\*

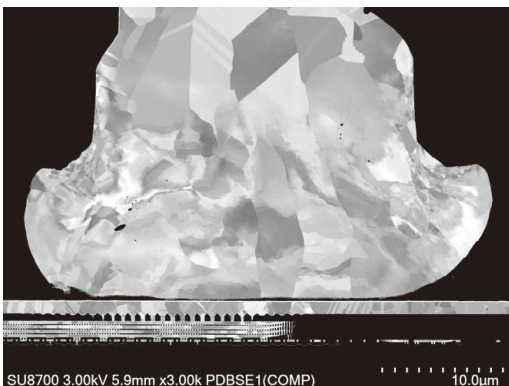

An essential capability of a BSE detector is the ability to acquire crystallographic as well as compositional information. The image on the left shows bonded gold wire's grains, voids and deformation at 3 kV to clearly demonstrate the PD-BSED's high sensitivity and ability to distinguish between structural components.

(\*) option

## Automated Optics Alignment

SEM operation requires optimization of various parameters when conditions, specimens, or analyses change. The SU8700 features an automated alignment function to assist in this procedure. From beam alignment to stigmator alignment, each alignment optimization can be done automatically.

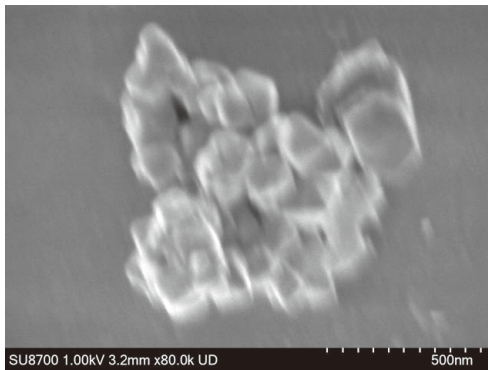

before alignment

Auto  
Alignment

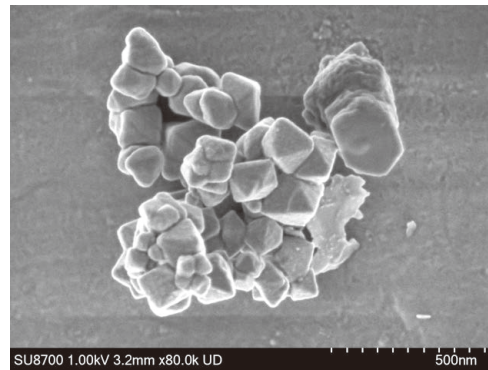

after alignment

## EM Flow Creator \*

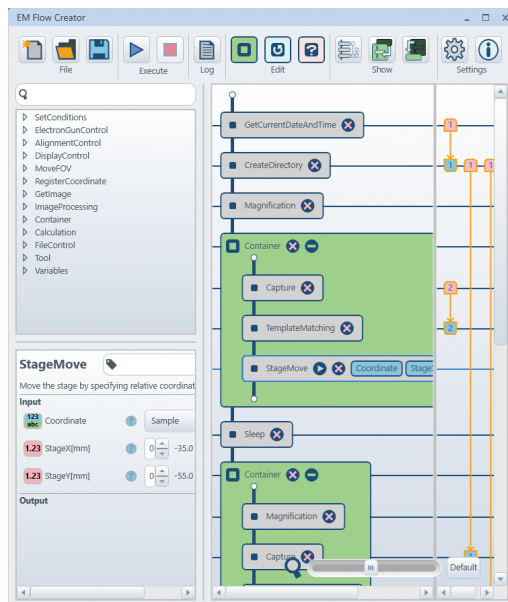

GUI of EM Flow Creator

EM Flow Creator" allows users to configure repeatable SEM operation sequences.

Various SEM functions can be assembled in EM Flow Creator' s window by drag-and-drop method then saved as a recipe for later use.

Once a recipe is configured, automated data collection under the set conditions can be performed with high accuracy and repeatability.

(1)

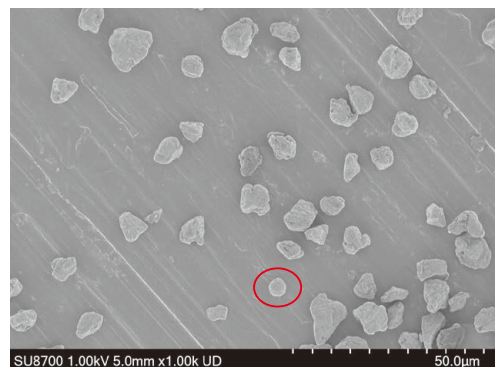

### Voltage Contrast Images of 7 nm process SRAM

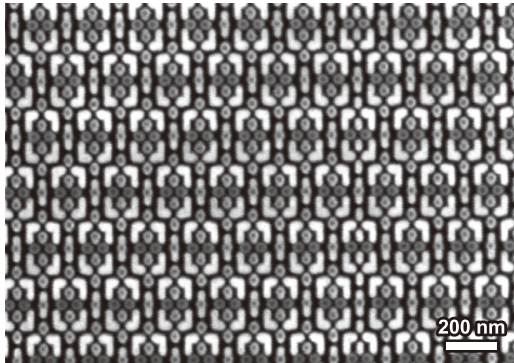

Voltage contrast in a SEM is a very powerful tool for semiconductor device evaluation. As the device structure changes by layer, SEM conditions such as accelerating voltage and contrast must also be optimized.

The SU8700 offers a voltage range down to 0.01 kV\*, without stage bias, to address these needs and more. On the left is an image taken at 300 V to demonstrate this VC capability as applied to the analysis of device architecture.

(\*) option

### Planview Image of 3D NAND Flash Memory

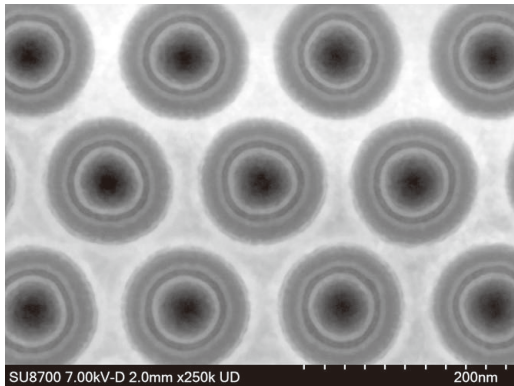

The image on the left shows analysis of memory cell structure for 3D NAND.

This data clearly shows structure consisting of very thin (<10 nm) nitride, oxide and poly-Si layers.

The high detection efficiency of the SU8700 allows for precise analysis of such features which are crucial to understanding capacitor structure.

**Automated detection and high magnification imaging example in three images below.**

- (1) Acquire image at 1kX to isolate a spherical particle (red circle)
- (2) Move to targeted particle and increase magnification, then acquire image at higher magnification.
- (3) Increase magnification further to observe the fine detail of the particle surface.

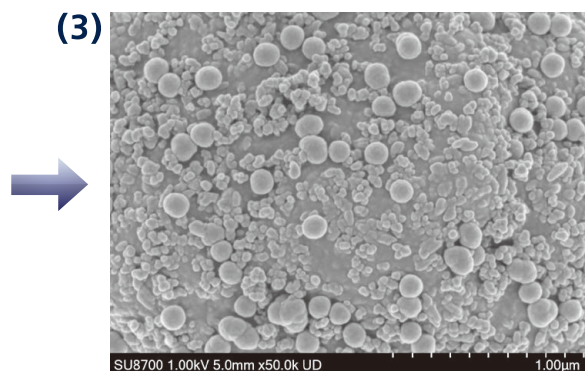
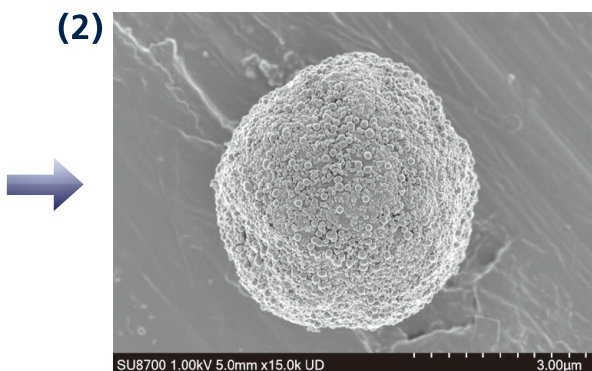

(\*) option

## Tempered Martensite in Steel

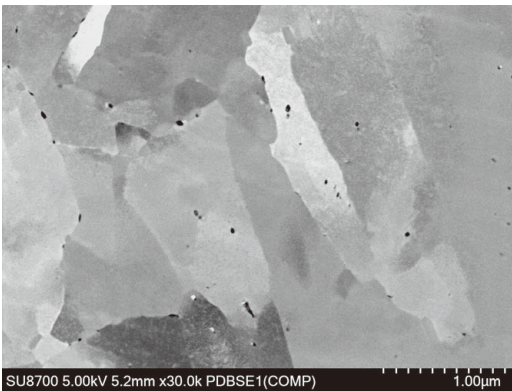
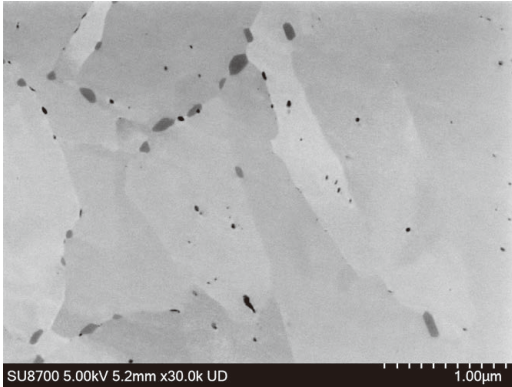

Detailed evaluation of metallic alloys is very important to many industries. The left two images demonstrate the strong capabilities of the SU8700 for such investigations. The precipitates along grain boundaries are clearly visible when acquiring secondary electron images using the UD. Grain size and deformation are easily distinguishable in left-bottom image by acquiring BSE channeling contrast. In addition, crystal defects in some grains can be clearly observed in right-bottom image by using the same method.

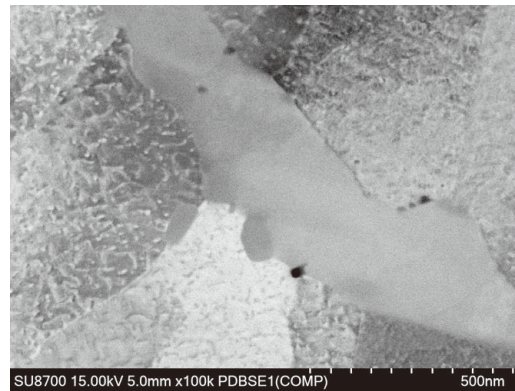

Specimen courtesy of Dr. Shoichi Nambu, The University of Tokyo

## Nanoparticles Containing Core-Shell Structure

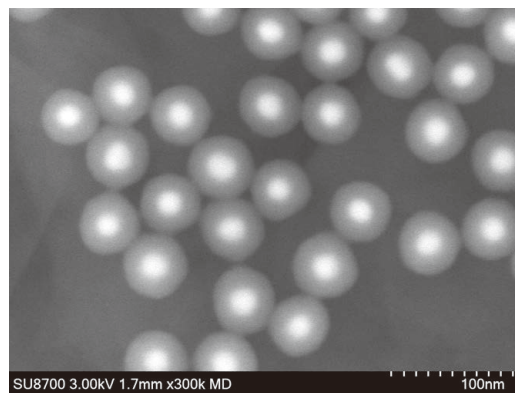
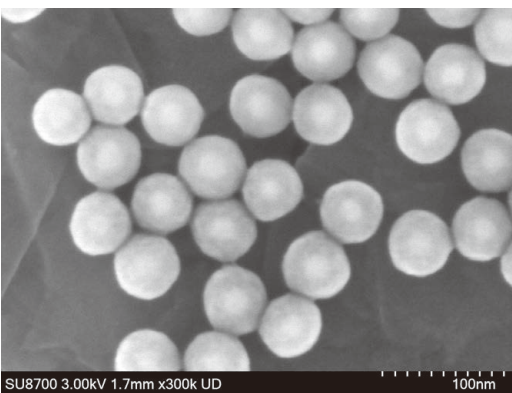

Many modern nanoparticles contain a core-shell design that is vital to their functionality. It is essential to measure size of both the core and the shell in morphological evaluation as well as functional characterization. In the left image above, fine surface structure is visible by SE signal (UD). In the Right image, Core (Ag) and Shell (SiO<sub>2</sub>) are easily distinguishable by BSE signal (MD).

### Ultrastructure of Arabidopsis thaliana

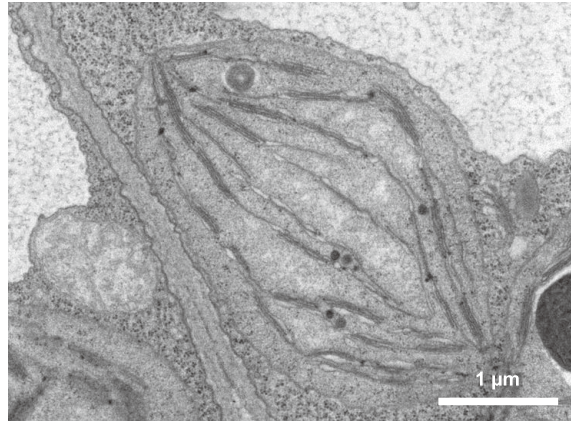
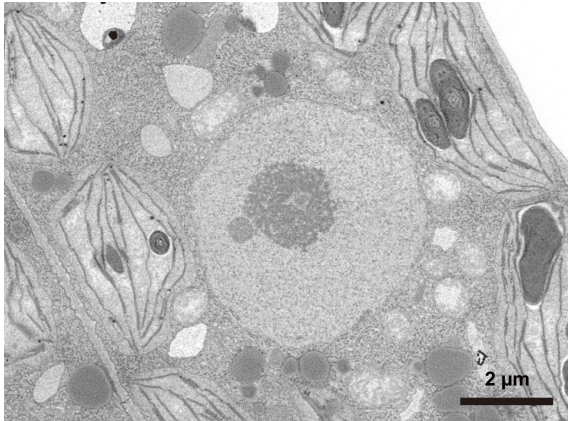

Backscattered electron images above from ultrathin section of Arabidopsis thaliana. Images were acquired at 2 kV of acceleration voltage to demonstrate TEM-like quality. For Energy Filtered BSE detection, ultrastructure such as thylakoid membrane are clearly visible in right image.

Specimen courtesy of Dr. Kiminori Toyooka, RIKEN CSRS

### Large FOV + High Pixel Resolution of Rat Cerebral Cortex

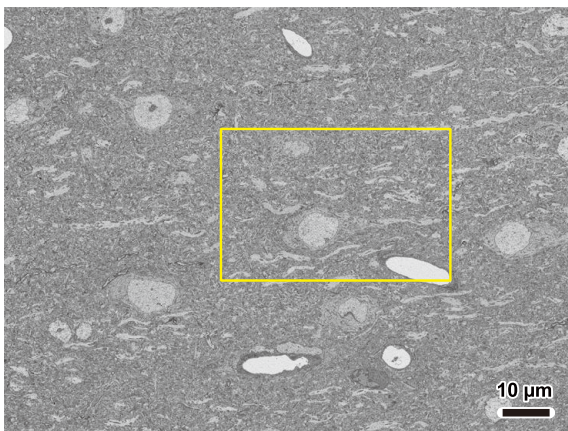

Three backscattered electron images from ultrathin section of rat forebrain demonstrate SU8700 image acquisition capability.

Top-left image was acquired with >120 μm of FOV. The yellow rectangle field in the image is also shown in bottom-left image with an increase of digital magnification. Right-bottom image is further digitally magnified and cropped from bottom-left image.

Even though digitally enhanced the original image more than 20 times, the structures of organelle are clearly visible and high-quality is maintained.

High pixel resolution image up to 40,960 x 30,720 pixel available (\*) on SU8700

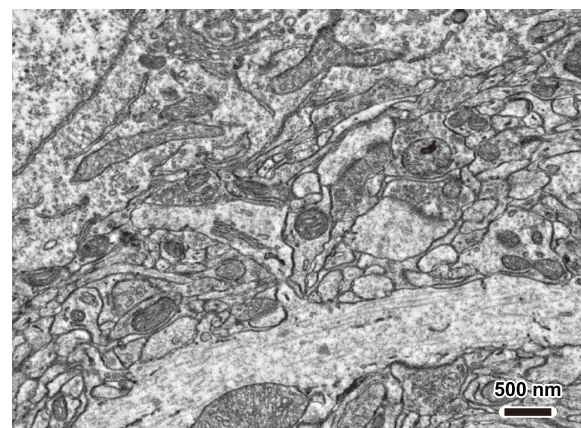
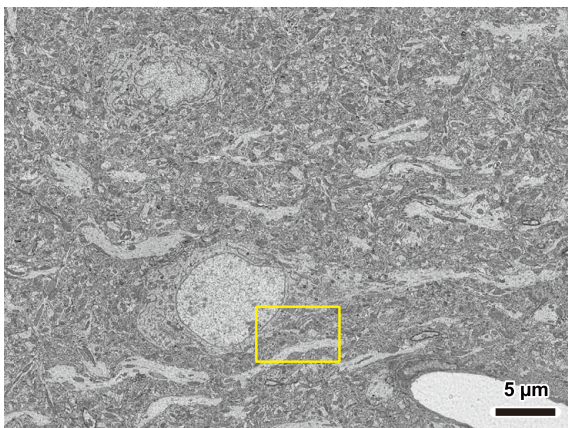

specimen courtesy of Dr. Yoshiyuki Kubota, Section of Electron Microscopy, National Institute for Physiological Sciences

(\*) option

# User Interface and Chamber

## Dual monitors with 6-signal simultaneous display

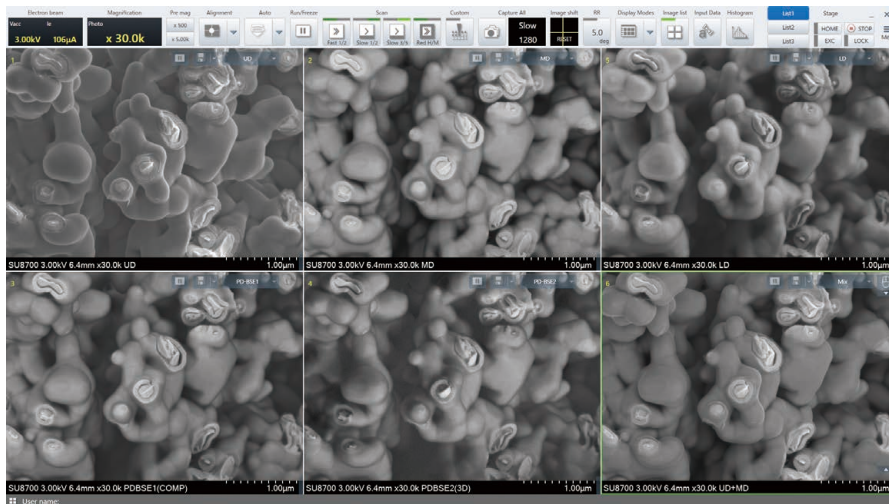

Multi-Channel image can be displayed on the screen. 2, 4 or 6 signals including the chamber scope(\*) or SEM MAP image can be displayed simultaneously on a single monitor. (top)

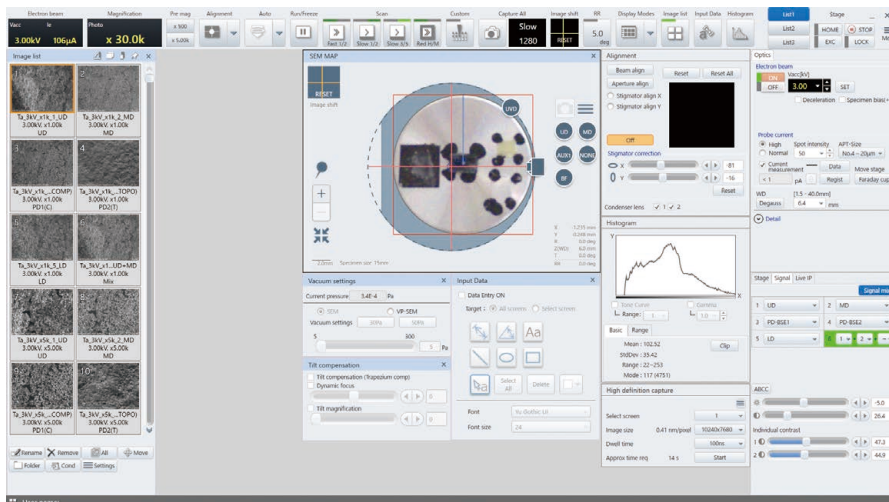

The dual-monitor configuration supports enhanced productivity plus expanded workspace and allows the operation panel to be customized with submenus positioned anywhere on either screen. (center)

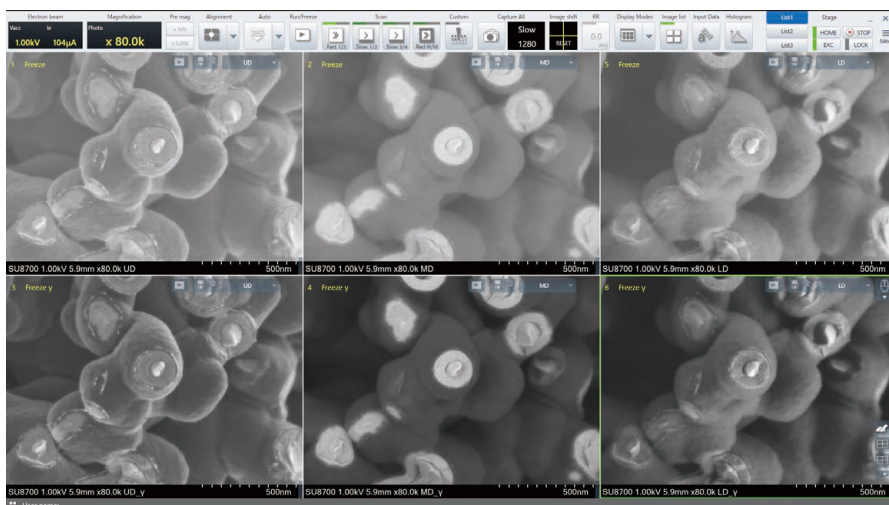

In multi-signal display mode, a saved image can be loaded to a vacant channel and further processed for real-time comparison to live conditions. (bottom)

## Operation assisting GUI

### Camera Navigation\*

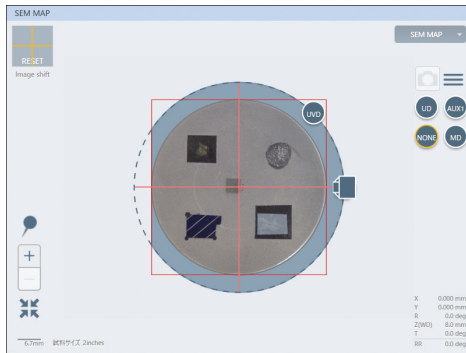

The built-in optical camera captures the specimen holder overview and is automatically transferred to the SEM MAP screen for a graphical navigation interface to assist with quick access ROI.

### Chamber Scope\*



GUI integrated chamber scope provides safe operation by showing specimen position in real-time. Monochrome/color convertible and can be displayed on individual window.

### Chamber and port layout

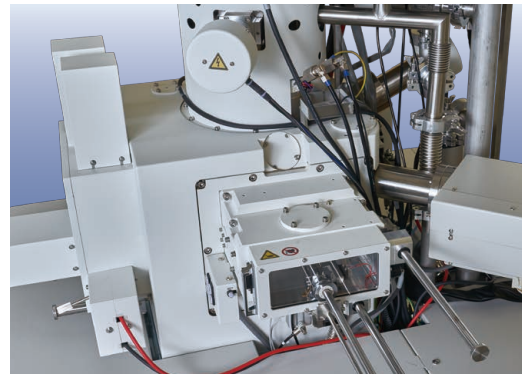
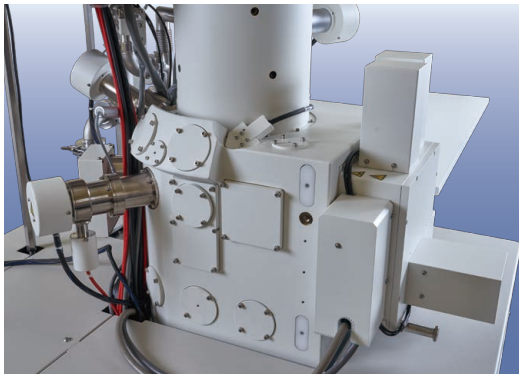

The specimen exchange chamber accepts large specimens up to  $\Phi 150$  mm diameter. Multiple EDS ports in the improved chamber design offer versatile analytical platform. (The instrument picture includes options)

